

# Roland<sup>®</sup> rental

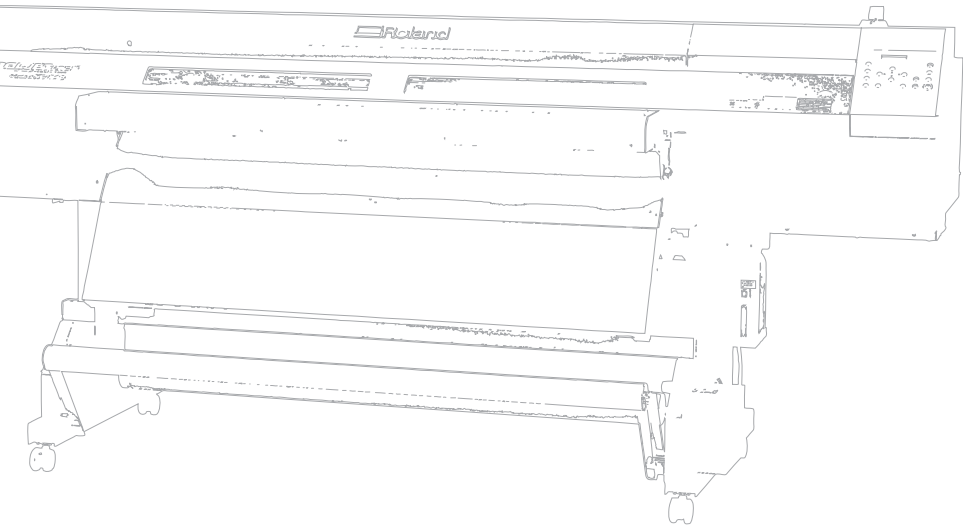

ec<sup>o</sup>  
lease

Imagine.  Roland<sup>®</sup>



TELOCHANA

1000

1000

## **ROLAND DG**

**Easy**

**No down payment**

**Tax deductible**

**Approval in 24 hours\***

**Low monthly payments**

## **What is Roland Rental?**

Roland Rental enables you to enjoy the use of Roland equipment throughout its useful life without the associated costs of ownership including up front capital investment.

Roland Rental offers a simple approval criteria and documentation to secure your Roland equipment.



## What are the benefits of Roland Rental?

### Simplicity and speed

Simple documentation and approval without the requirement of financial statements for sums up to \$35,000 ex gst (subject to credit criteria).

### 100% tax deductible

Rental payments are an expense item for reporting purposes and are 100% tax deductible when equipment is used for business purposes.



### Conserves cash

Small monthly payments rather than one large upfront payment.

### Fixed monthly rental payments

Fixed payments throughout the term make budgeting easy.

### No Residual responsibility

You have no large lump sum to pay at the end of term, simply pay one more monthly repayment and own it!

### Government, Education and Corporate sectors

Rental payments are pure operating expense and may not require capital expenditure approval

## Who is eligible?

The approval criteria as follows:

- Businesses that have been established for a minimum of two years and are registered for GST
- Business owners/directors are confirmed property owners
- Business and Owners have a clear credit history
- Transactions over \$35,000 require business financial statements



## The Rental Comparison

Benefit	Rental	Traditional Lease	Cash Purchase
Conserve cash - Pay for use over time	✓	✓	✗
Fixed regular payments	✓	✓	✗
Bundling of hardware, software, maintenance and services	✓	✗	✓
Payments fully tax deductible	✓	✓	✗
No Financial Statements required	✓	✗	✓
Fast turnaround and approval	✓	✗	✓
Off balance sheet	✓	✗	✗

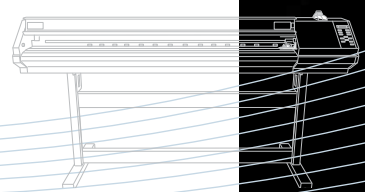

## Commonly asked Questions

### Who is Ecolease?

Ecolease manage the Roland Rental program on behalf of Roland DG. Capital Finance Australia Limited is the underwriter.

### What is the interest rate?

Unlike a loan, no interest rate is charged because you're paying for the use of the equipment over a fixed term. You are not repaying a loan.

### What if I want to upgrade to new equipment during the rental term?

That's OK. We simply adjust the rental agreement to incorporate the cost of the new equipment and establish a new term.

### Are the payments tax deductible?

Yes - up to 100%, depending on the portion of usage for the business.

### What happens if something goes wrong with the equipment?

Outside the manufacturers standard warranty it is the responsibility of the customer to ensure the equipment is maintained in good working order at all times (less fair wear and tear).

### Can I add on equipment to my existing rental agreement?

Organising additional equipment during the rental term is simply a matter of signing off on a rental document that runs beside the existing one. This allows you to increase your rental equipment without extending the term, or to add equipment and extend the term so that the rental payments are similar to your current agreement.

### Do the rental payments include insurance?

It is the responsibility of the customer to ensure the equipment is insured at all times.

### Who owns the equipment?

You own the equipment at the end of the agreed contract term for one extra repayment.

### Can I cancel and hand back the equipment before the end of term?

If you return the equipment before the end of term you must pay for the balance owing. Most clients prefer to upgrade to new equipment and take out a new rental agreement.





## What next?

### 3 simple steps:

1. Complete the Roland Rental Document.
2. Approval process is 24 hours\*
3. Once approved your Authorised Roland dealer will notify you to finalise the transaction and organise delivery.

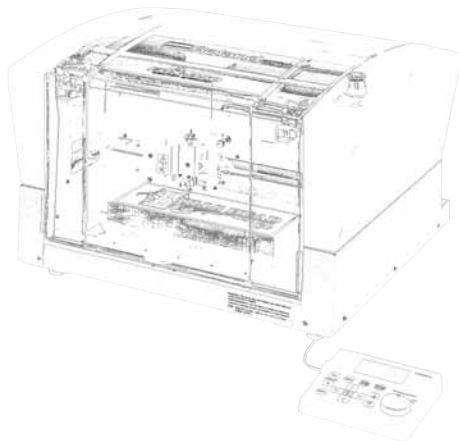

\* Once application is received by Ecolase

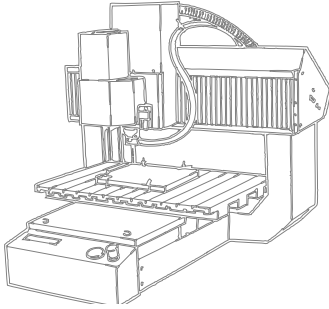

# Roland<sup>®</sup> rental



[www.rolanddgcare.com.au](http://www.rolanddgcare.com.au)

